

genexis 

# FiberTwist

P2410C/P2411C

Installation Guide





PLEASE READ THIS PRODUCT GUIDE AND SAFETY INSTRUCTIONS BEFORE INSTALLING OR USE OF THE PRODUCT. AS RECIPIENT OF THE PRODUCT, YOU ARE RESPONSIBLE TO GET FAMILIAR WITH THE PRODUCT GUIDE AND SAFETY INSTRUCTIONS BEFORE USING THE PRODUCT. CONTACT YOUR SERVICE PROVIDER IN CASE OF ANY QUESTIONS.

## Installation guide

### Box contents

- Genexis FiberTwist (active device)
- Power adapter
- Labels (self-adhesive)

### Label position

The product label is positioned on the back of the active device.

### Preparation

Ensure there is a power socket within reach of where the device is being installed.



### Important:

Instructions need to be followed precisely and uninterrupted. This minimizes the risk of damage to the fiber optic connectors, causing a severe degradation of signal quality.

## Button overview

The debossed buttons are positioned vertically at the right side of the housing

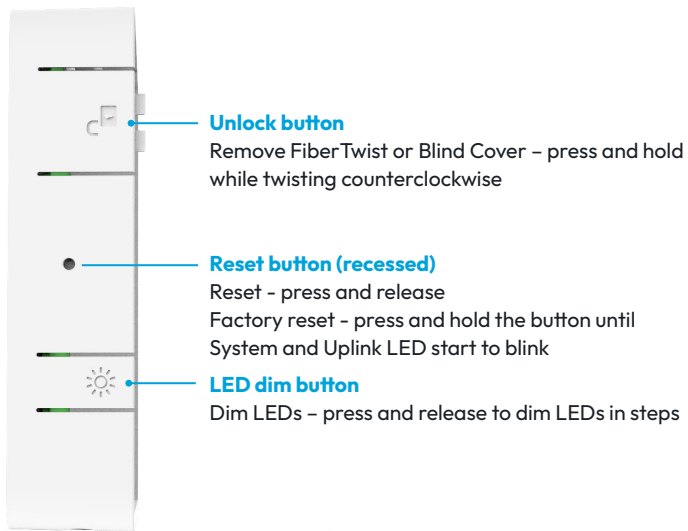

## LED overview

The debossed front LEDs are positioned horizontally at the center of the housing.

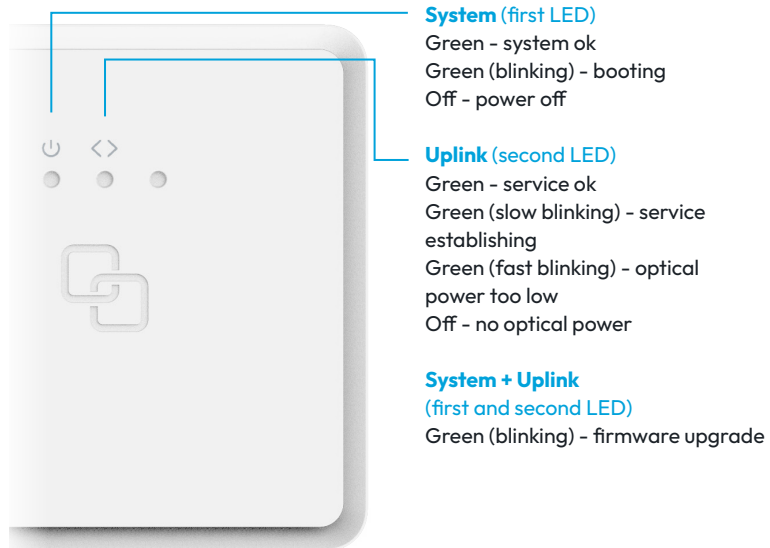

## Port overview

The interface buttons are located from left to right.

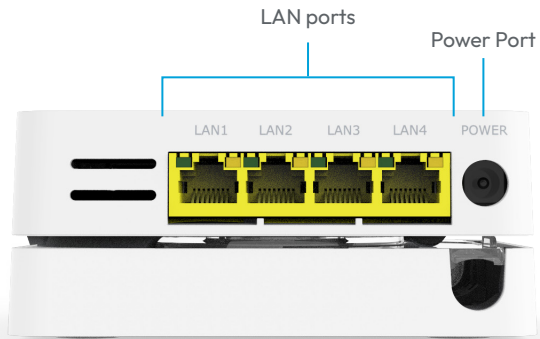

### Remove Blind Cover (if present)

1. Press and hold the unlock button (see button overview).
2. Rotate the Blind Cover counterclockwise till it blocks.
3. Remove the Blind Cover from the baseplate (FTU) by pulling it towards yourself.
4. Store the Blind Cover in a safe place.

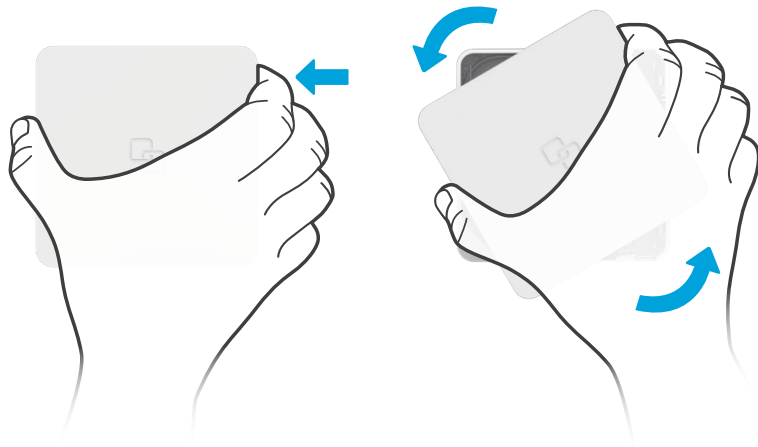

### Remove dust cap

1. Take the FiberTwist out of the box.
2. The dust cap is connected to the red string located on the rear of the FiberTwist.
3. Remove the dust cap by pulling the red string.
4. Store the dust cap in a safe place.

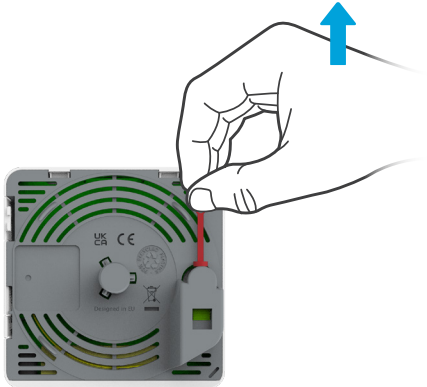

### Twist!

1. Place the FiberTwist on the FTU as shown in the picture below, in a 30-degree angle.
2. Rotate clockwise until it clicks into place.
3. Make sure the FiberTwist is aligned squarely on the FTU, each edge must line up directly with the FTU below.

Your FiberTwist is now installed!



## Connecting the Fiber Twist

1. Connect your gateway to a LAN port via an RJ45 network cable.
2. Connect the supplied power adapter to the FiberTwist and plug the adapter into a power socket.

If at some point in the future it becomes necessary to uninstall the FiberTwist, please place the Blind Cover back on the FTU immediately and put the dust cap back on the FiberTwist.

**Warning:** This product contains a laser that emits invisible light. It is a Class 1 Consumer Laser product according to EN 50689:2021. However, it is still advised to not look directly into the fiber connector when the product is powered on.

**Warning:** Do not cover the device, this will interfere with the ventilation. Ambient Operating Temperature: 0 - 40°C / 32 - 104°F.

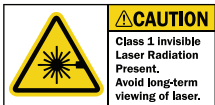

Security vulnerabilities can be reported at:  
<https://genexis.eu/about/security>



## Safety guidelines

Use the following safety guidelines to ensure your own personal safety and to help protect your product from potential damage. To the extent permissible by applicable law, failure to follow these guidelines could result in damage to your product, which might not be covered by Genexis warranty.

To reduce the risk of injury, electrical shock, and fire observe the following precautions:

- Operate the product only from the type of external power source indicated on the electrical label of the power supply.
- Use only the power adapter supplied with the product. In case of malfunctioning contact your service provider for replacement.
- The electrical socket-outlet should be easily accessible to contain the power adapter. The plug must be fully inserted in the electrical socket-outlet with no part of the blades exposed.
- Observe extension cords and power strip ratings. Make sure that the total ampere rating of all products plugged into the extension cord or power strip does not exceed 80 percent of the ampere ratings limit for the extension cord or power strip. Check the extension cords and power strips regularly. If they are damaged, replace them immediately.
- Do not push any unintended objects into the openings of your product. Doing so can cause fire or electrical shock by shorting out interior components.
- Do not open or try to open the product. Opening or removing the covers can expose you to electrical shock. Genexis recommends that only a trained technician services components inside these compartments.
- Do not install or use the product during a lightning- or thunderstorm. There is a remote risk of electric shock from lightning.
- This product contains a Class 1 laser that emits invisible light. Do not look directly into the optical port without any eye protection when powered on.

To reduce potential damage to the equipment, observe the following recommendations:

- This product is designed for indoor use only in a temperature controlled (0 - 40°C / 32 - 104°F) and humidity-controlled (5-95% relative humidity) environment.
- Do not service any product but contact your service provider.
- When placed vertically mount the product stable to a flat surface using applicable screws and plugs. Do not place any objects on top of the product which may damage the product.
- Place the product and cables out of reach of pets. They could damage them and cause injury

- or electrocuting.
- If any of the following conditions occur, unplug the product from the electrical outlet and replace the part or contact your service provider:
  - › The power adapter or power cable is damaged.
  - › The network cable or optical cable is damaged.
  - › An object fell onto the product.
  - › The product was exposed to water.
  - › The product was dropped or damaged.
  - › The product does not operate correctly when you follow the operating instructions.
- Keep your product away from radiators and heating sources and do not block cooling vents. Prevent installing the product in direct sunlight. Blocking the ventilation holes may cause fire due to overheating.
- Do not spill food or liquids on your product, and never operate the product in a wet or steam environment. Do not touch the product or its power adapter with wet hands. If the product gets wet, unplug the product from the electrical outlet and contact your service provider. Any liquid could have damaged interior components causing a shortcut in the product.
- Do not use liquid, aerosol cleaners or any harsh chemicals to clean the product. Unplug the product and use a soft, dry cloth for cleaning the product.
- Position power cables, network cables and optical cables carefully. Route cables so that they cannot be stepped on or tripped over. Be sure that nothing rests on any cables.
- When connecting an electronic device to the product, make sure to use the recommended network cable and connect the device to the right port of the product. Incorrect connections may damage the device and/or the product.

## FCC Compliance Information Statement

This device has been tested and found to comply with the limits for a Class B digital device, pursuant to part 15 of the FCC Rules. These limits are designed to provide reasonable protection against harmful interference in a residential installation. This equipment generates, uses and can radiate radio frequency energy and, if not installed and used in accordance with the instructions, may cause harmful interference to radio communications. However, there is no guarantee that interference will not occur in a particular installation. If this equipment does cause harmful interference to radio or television reception, which can be determined by turning the equipment off and on, the user is encouraged to try to correct the interference by one or more of the following measures:

- Reorient or relocate the receiving antenna.
- Increase the separation between the equipment and receiver.
- Connect the equipment into an outlet on a circuit different from that to which the receiver is connected.
- Consult the dealer or an experienced radio/TV technician for help.

**Product Name:** 1G PtP Network Terminal

**Model Number:**  
FiberTwist-P2410C  
FiberTwist-P2411C

**Responsible party:** Genexis Broadband, LLC

**Address:** 228 E 45th St, Ste 9E,  
New York, NY 10017

**E-mail:**  
Info.na@genexis-broadband.com

**Name and title of authorized person**  
Maarten Egmond, CTO  
Genexis Netherlands B.V

**Signature of authorized person**



**Place of issue**  
Eindhoven  
The Netherlands

**Date of issue**  
2026-02-05

## EU Declaration of Conformity

Hereby, Genexis Netherlands B.V. declares that the products FiberTwist-P2410C and FiberTwist-P2411C are in compliance with Directive 2014/30/EU, Directive 2014/35/EU, Directive 2009/125/EC, Directive 2011/65/EU and Delegated Directive 2015/863, Directive 2019/882/EU.

The full texts of the EU declaration of conformity is available at the following internet address:

<https://genexis.eu/product/fibertwist-p2410c>  
<https://genexis.eu/product/fibertwist-p2411c>

**Company Name**  
Genexis Netherlands B.V.

**Company Address**  
Lodewijkstraat 1a  
5652 AC Eindhoven  
The Netherlands

**Name and title of authorized person**  
Maarten Egmond, CTO

**Signature of authorized person**



**Place of issue**  
Eindhoven  
The Netherlands

**Date of issue**  
2026-02-05

At Genesis, we strive for  
**a more sustainable future**  
with our devices.

**90% recycled**

plastics used  
in this device.

**Energy-efficient**

to save both energy  
and costs for you.

**Designed to last**

for a second life if  
treated carefully.

 **Something you  
can do!**

Revision 1.1 - February 2026 - Copyright © 2026 Genesis Netherlands B.V. All rights reserved.

Genesis assumes no responsibility for any inaccuracies in this document. Genesis reserves the right to change, modify, transfer, or otherwise revise this publication without notice.